

Femap · NX · Tecnomatix

Kotchergenko

Adoption of Siemens PLM Software tools enables company to increase its service offerings; gain competitive edge

Industry

Industrial machinery and equipment

Business challenges

Integrate machinery and structural design software with other internally developed engineering systems

Find software that reduces the cost of finite element analysis

Keep up with the company's growth rate

Expand business with both existing and new clients

Keys to success

Easy integration of Femap with NX Nastran with other engineering systems

Reduced licensing cost, better quality and higher level of support

Reliable supplier

Appropriate software upgrades

More comprehensive solutions portfolio via Plant Simulation

Femap with NX Nastran becomes vital component in company's best practices; use of Tecnomatix for logistics analysis allows company to fulfill a critical service gap

The highest quality technical engineering services

Kotchergenko Engenharia (Kotchergenko) was founded in 1993 to fill a technological gap that existed between machinery and structural design. Since its inception, the company's plan has been to differentiate itself from the competition through high-quality technical engineering services.

To realize a unique service offering, Kotchergenko uses a combination of solutions, including externally acquired state-of-the-art software and internally developed custom applications. These solutions address a wide variety of engineering issues, such as upgrading equipment

and investigating accidents involving machinery and structures.

Why Siemens PLM Software

The first market-based product lifecycle management (PLM) system used by Kotchergenko Engenharia was Ansys® software, which wasn't well-suited to handling the company's integration requirements at a time when the company needed it to sustain its growth. "The software's architecture was limited, and its cost was too high," says Frederico Mol, technology director at Kotchergenko.

Since the software license was about to expire and the company was experiencing a period of notable growth, Mol decided to look for another supplier that could offer a high-quality product capable of being integrated with other internal systems and at a reasonable cost. Mol explains that the company needed to integrate the systems that perform standards-based verification procedures of equipment with its main software.

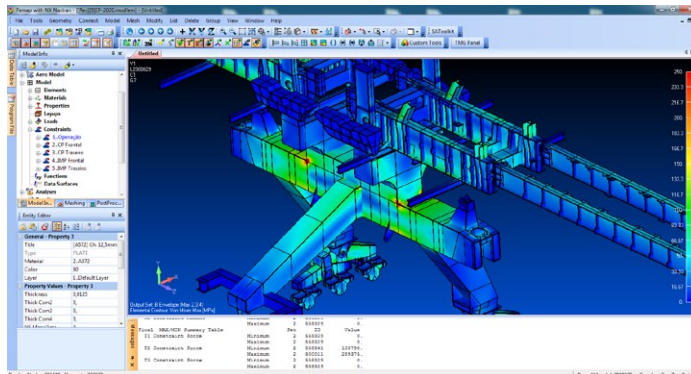

Results

50 percent increase in overall productivity

20 percent faster model generation

25 percent improvement in information flow/sharing

Significantly improved project quality/reliability

Enhanced ROI

“We thoroughly reviewed Tecnomatix and decided to also acquire licenses a couple of months ago, because we concluded the software would give us more new solutions to our portfolio. Not only did we consider Tecnomatix as the best option for us, we also felt comfortable acquiring it, because of our previous relationship with Siemens PLM Software and the great support the company has provided.”

Frederico Mol
Technology Director
Kotchergenکو Engenharia

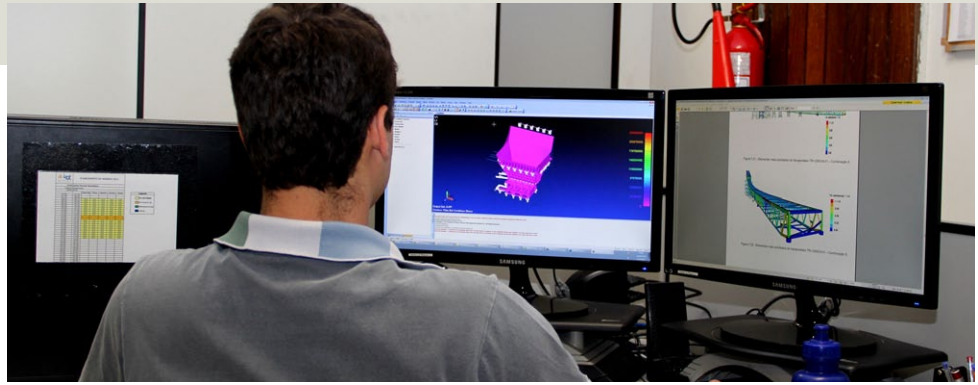

Given that the company had acquired Femap™ with NX™ Nastran® software last year, it decided to do additional research on Siemens PLM Software’s solutions and discovered Tecnomatix® software.

“We thoroughly reviewed Tecnomatix and decided to also acquire licenses a couple of months ago, because we concluded the software would give us new solutions to our portfolio. Not only did we consider Tecnomatix as the best option for us, we also felt comfortable acquiring it, because of our previous relationship with Siemens PLM Software and the great support provided,” concluded Mol.

At Kotchergenکو, Femap with NX Nastran is used to conduct structural design calculations through the finite element analysis (FEA) method. A numerical tool for problem solving that is widely used in machinery and structural analysis, Femap with NX Nastran plays a key role in Kotchergenکو’s core service, which consists of using simulation tools to verify clients’ machinery and recommending how to increase their production according to the equipment’s capacity, while also taking into consideration various requirements, such as durability, strength and safety. “Since design methods have evolved substantially, manufacturers are under more pressure to improve their products, reduc-

ing weight and therefore costs; however, their specifications do not always match market requirements,” notes Mol. “After we conduct our diagnosis, our clients are better prepared to question manufacturers and request changes to match product performance within expectations.”

Vital business component, substantial gains

With most projects utilizing Femap with NX Nastran, the solution has become a vital component in the company’s best practices. “We could have developed such software internally, but this would have demanded a great investment in terms of man hours and effort in an activity that is not part of our core competencies,” says Mol. “Our business is to provide engineering services. For some projects, the systems are designed internally in order to address specific standards that are required by the clients.”

By adopting Femap with NX Nastran, Kotchergenکو is generating its models approximately 20 percent faster. The company has also achieved substantial cost savings as well as measurable gains in project quality and reliability. Importantly, with Femap with NX Nastran, the company can easily scale the software to its needs. Six licenses were acquired and more licenses appear imminent as the company is growing rapidly. Last year, the company posted a 77 percent increase in billings.

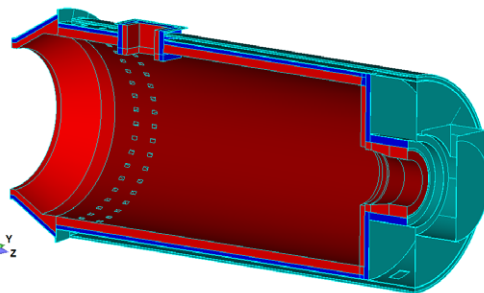
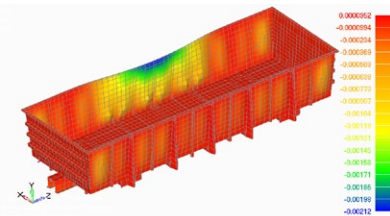

Solutions/Services

Femap with NX Nastran
www.siemens.com/plm/femap
Tecnomatix
Plant Simulation
www.siemens.com/tecnomatix

Customer's primary business

Kotchergenko Engenharia provides structural/mechanical analysis, evaluation and review of equipment projects developed by third parties.
www.kot.com.br

Customer location

Belo Horizonte, Minas Gerais
Brazil

"Use of Plant Simulation helps increase our profitability as well as improves the accuracy of services provided to both new and existing clients."

Frederico Mol
Technology Director
Kotchergenko Engenharia

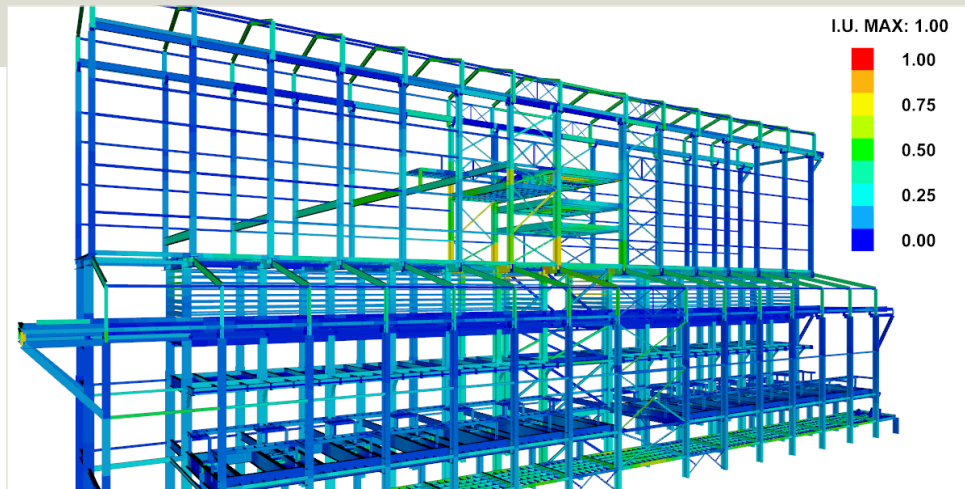

Adding Plant Simulation for logistics analysis

The Plant Simulation solution in the Tecnomatix portfolio is used for projects that have just started. "Plant Simulation allows us to conduct logistics analysis," says Mol. "This, in turn, allows clients to assess the feasibility of an operation by doing a simulation with the product, either in transportation, loading, or the processing of the extracted mineral, until it reaches the nearest port for shipping. We had the demand, but we didn't have the solution to offer; now we are prepared, because we understand the business opportunities at hand." Mol notes, "Use of Plant Simulation helps increase our profitability as well as improves the accuracy of services provided to both new and existing clients."

Plans for continuous process improvement, new consulting services

Currently, the entire company routinely uses Femap with NX Nastran, which forms the core of the company's systems as all the others have to be integrated with this solution. Mol is convinced the tool meets all the needs related to finite element design calculation, and that it can be updated as needed. For Mol, each update is extremely accurate, and always contributes to improving processes.

One of the Kotchergenko's goals is to increase the number of licenses it obtains from Siemens PLM Software, while it continues to grow. The company's plans also include offering new consulting services, such as the logistics analysis services enabled by Tecnomatix and, in doing so, it hopes to diversify its client portfolio. Mol notes that the systems also helped Kotchergenko in its International Organization for Standardization (ISO) 9000 quality certification process.

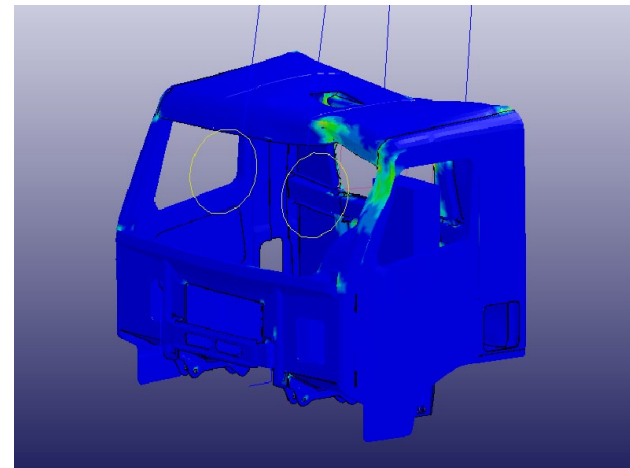

Siemens Industry Software

Americas +1 314 264 8499
Europe +44 (0) 1276 413200
Asia-Pacific +852 2230 3308

www.siemens.com/plm

© 2013 Siemens Product Lifecycle Management Software Inc. Siemens and the Siemens logo are registered trademarks of Siemens AG. D-Cubed, Femap, Geolus, GO PLM, I-deas, Insight, JT, NX, Parasolid, Solid Edge, Teamcenter, Tecnomatix and Velocity Series are trademarks or registered trademarks of Siemens Product Lifecycle Management Software Inc. or its subsidiaries in the United States and in other countries. Ansys is a trademark or registered trademark of Ansys, Inc. or its subsidiaries in the United States and other countries. Nastran is a registered trademark of the National Aeronautics and Space Administration. All other logos, trademarks, registered trademarks or service marks used herein are the property of their respective holders.

Z18 33073 4/13 A